

AF 50S

silicon variant of AF 50

The **AF 50S facade system** is characterised by its high-level aesthetics and light build. This modern design perfectly complements office buildings by enhancing their attractiveness and class. This system allows for the use of slim, 20 mm multi-glazing. This solution influences thermal parameters so it is suitable for (ever) changing weather.

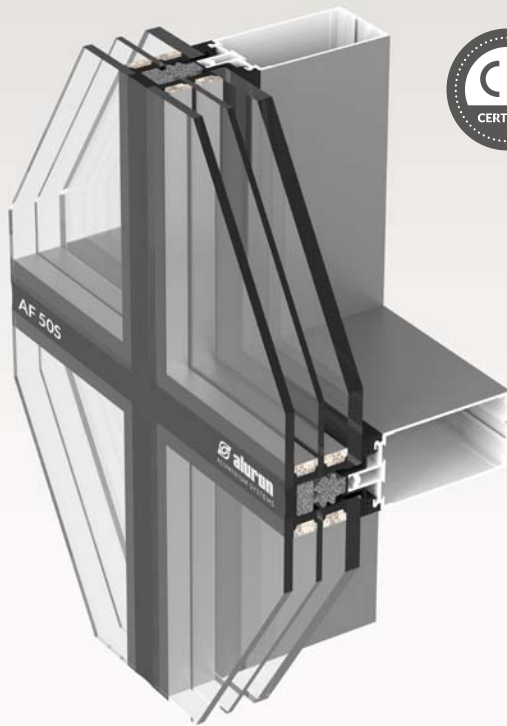

THREE WAYS OF GLAZING:

- Point connection to embedded fasteners
- Glued frame grip
- Inner frame support
- Possibility of creating vertical or horizontal lines

SELECTED FEATURES AND SYSTEM PARAMETERS

Glazing range	up to 62 mm
Windowless wall air permeability	AE 1650 Pa
Water tightness	RE 2500 Pa
Facade's thermal insulation U	from 0,60 W/m ² K
Glazing weight capacity	up to 500 kg
Inter glazing joint	20 mm
Lintel - sill strips are available with fire resistance	EI 30 & EI 60

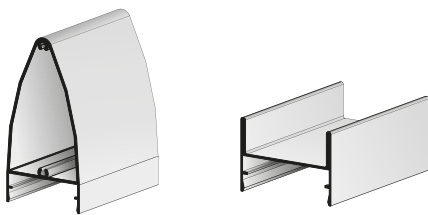

Profile shapes of external coverings

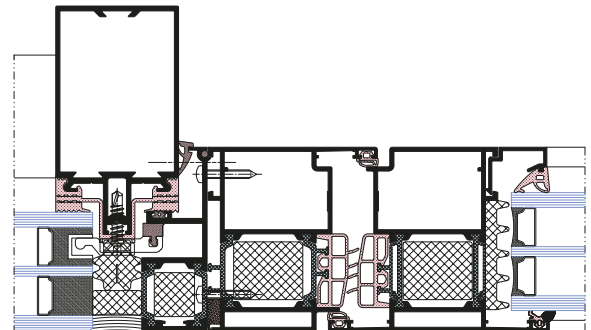

Facade and door connection

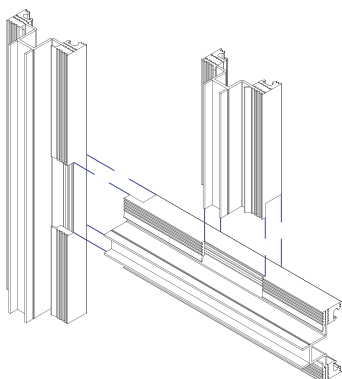

3-stage drainage with internal mullion gasket

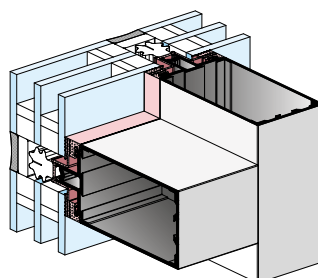

Profile and gasket flushed on the inner side of the facade

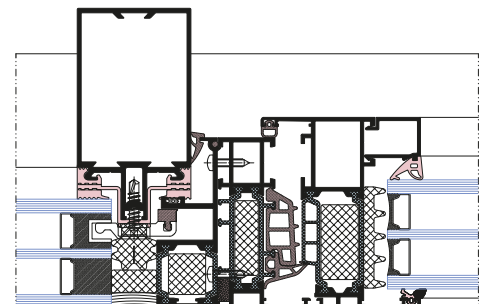

Facade and window connection